

MODERN CASTINGS CLEANING EQUIPMENT  
AFS Castings Congress  
May 10, 1966

Part I

Presented by: J. J. Janush

Marketing Manager  
The Wheelabrator Corporation

Some of the most exciting and dramatic changes in foundry technology are taking place in the cleaning room. To keep pace with today's high production requirements and tough finishing specifications, slow, inefficient cleaning machines are being replaced by new, different and often novel solutions to specific cleaning problems.

The old, standard, batch tumbling mill machines are being widely replaced by heavy duty, 'Super Tumblast' types of batch cleaning equipment. Work handling methods can be mechanized to any desired degree including fully automatic handling.

The loader (Fig. 1) is often designed to fit special requirements such as tote box loading or, automatic loading through the use of load sensing devices. Automatic unloading is accomplished by placing a shaker conveyor between the machine and loader. The conveyor accepts the castings from the machine and moves them to a container.

In this automatic cleaning line (Fig. 2) tote trucks empty their loads into the recessed loader bucket. After cleaning, the castings are automatically reloaded into the tote trucks.

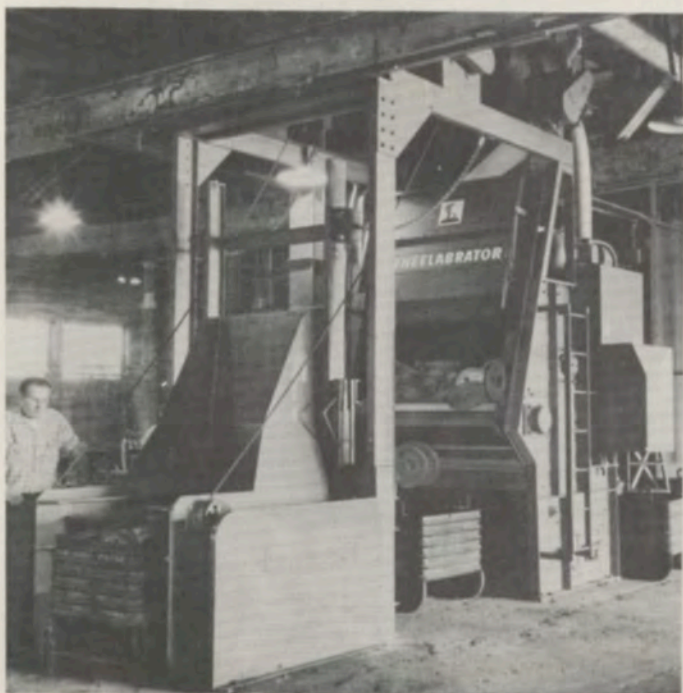

Fig. 1

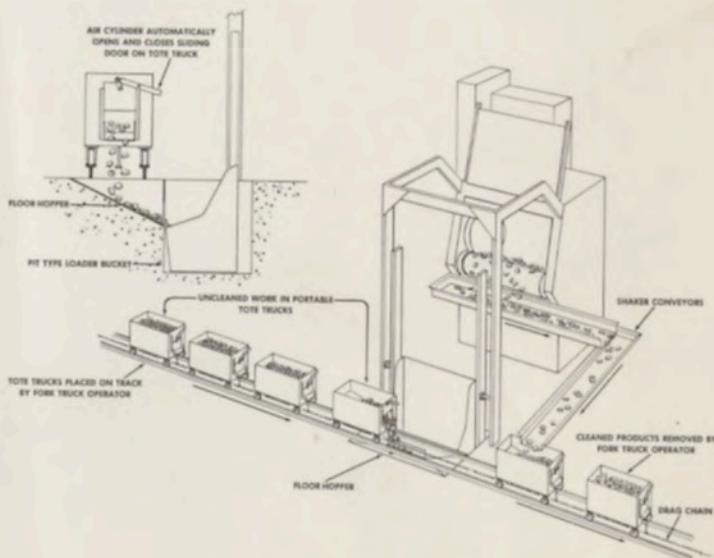

Fig. 2



To meet varying production requirements, heavy duty batch type machines are made in a wide range of sizes from 7 cubic feet to 100 cubic feet capacity. Typically, a 7 cubic foot machine might be used to clean malleable castings (Fig. 3) while the worlds largest batch type machine cleans 100 cubic feet of steel castings weighing up to 15 tons each (Fig. 4).

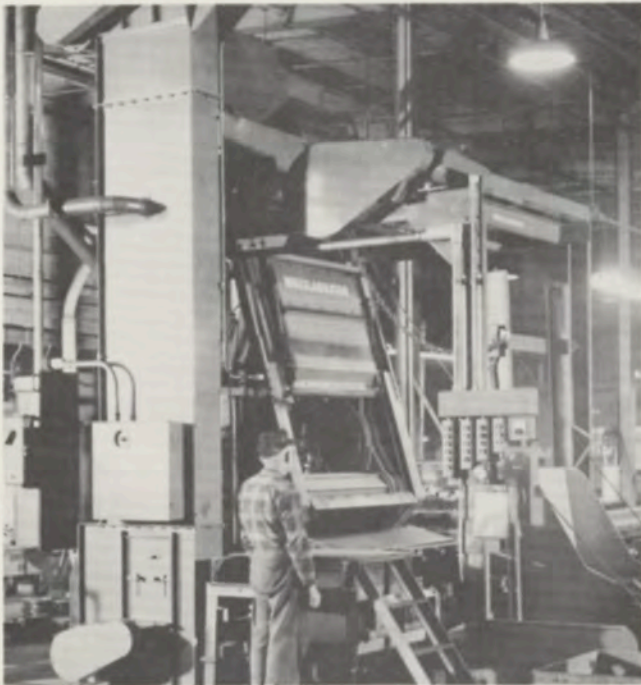

Fig. 3

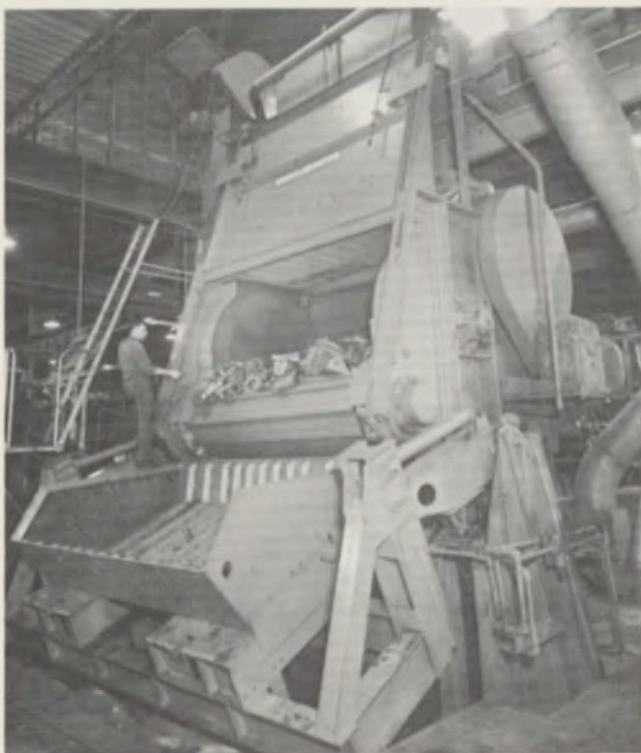

Fig. 4

A revolutionary development in cleaning room operations is the combination core-knockout and blast cleaning machine. For example, castings weighing 192 pounds each, having a total core and moulding sand weight of 149 pounds, are cleaned without difficulty. When this much sand is introduced into a blast machine, it takes a special sand removal system to keep machine maintenance costs from skyrocketing.

Here is how the separator system works (Fig. 5). Sand and abrasive, during the core-knockout blast cycle, flows to the primary separator which removes a large percentage of the sand. Abrasive, and the remaining sand, then flows to a surge tank where it is temporarily stored while the core-knockout cycle is completed. When the normal blast cleaning cycle begins, the sand and abrasive mix is metered back through the primary separator. Practically all of the sand is removed in this second pass. Finally, this abrasive, and abrasive coming directly from the normal blast cleaning cycle, flows through a secondary separator for final cleaning.

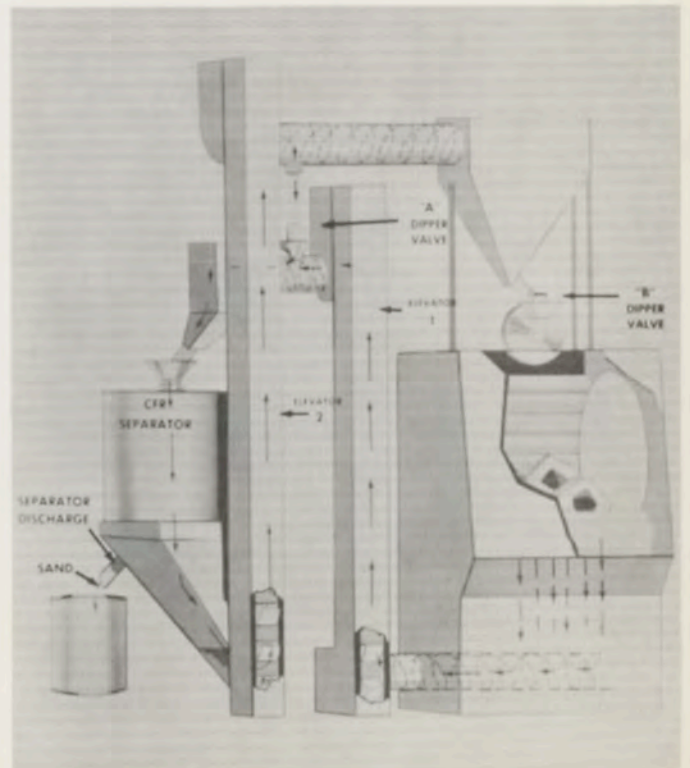

Fig. 5



The 34 cubic foot machine, shown in Figure 6, is typical of the combination core-knockout and blast cleaning batch type machines now operating in many foundries. The volume of sand in typical loads run from 1,100 to 1,600 pounds. The entire cleaning cycle takes 6 minutes.

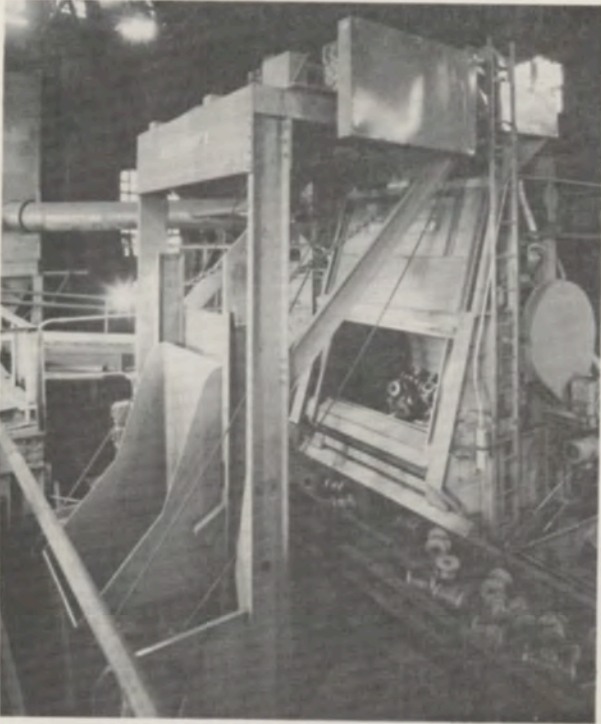

Fig. 6

The advantage of combination core-knockout and blast cleaning of extremely large castings are particularly attractive. Removal of cores from such pieces has always been a time consuming and costly operation. For example, removing cores from a 4,000 pound casting (Fig. 7) had been a 9 hour operation, followed by laborious cleaning in an airblast room.

Now, the same work is done in 10 minutes in a Swing Table type airless blast machine (Fig. 8). This Swing Table machine has two (2) 96" diameter work tables each of which will accommodate loads weighing up to 10,000 pounds and 120" long. As a result of using this combination core-knockout blast cleaning machine, labor has been reduced approximately 60%. About 90% of the core rods and nails are reclaimed as is most of the sand.

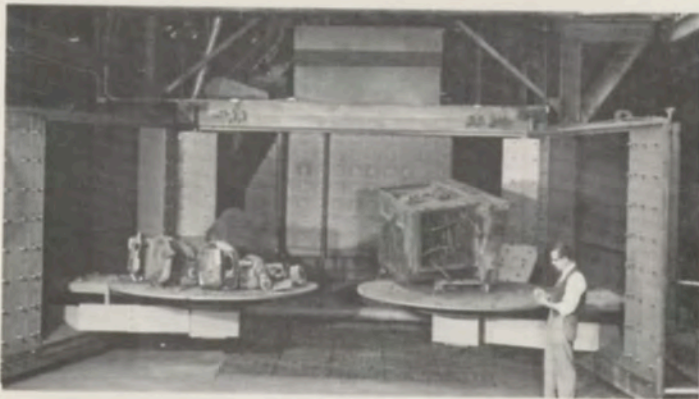
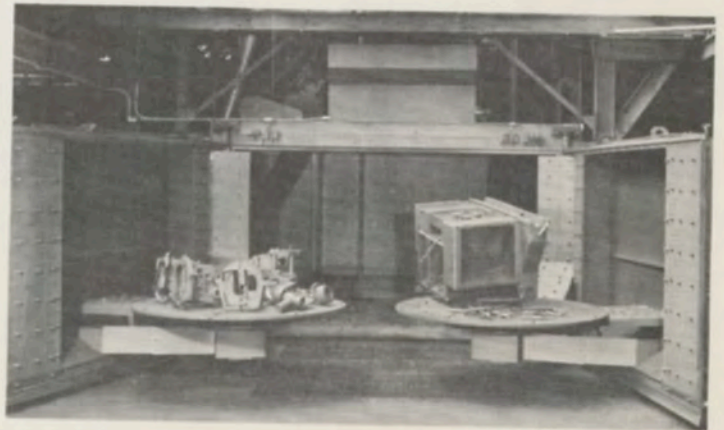

Fig. 7

Fig. 8





At an Eastern steel foundry, extremely large castings weighing up to 100 tons each were formerly cleaned by high pressure water blasting, manuel chipping and other slow and costly methods. For example, it used to require 14½ man hours of chipping and water blasting to come anywhere near bare metal on a 35 ton casting (Fig. 9). Now, the same casting is cleaned in just 55 minutes...25 minutes of automatic blast cleaning followed by 30 minutes of hand, airblast cleaning of interior areas (Fig. 10).

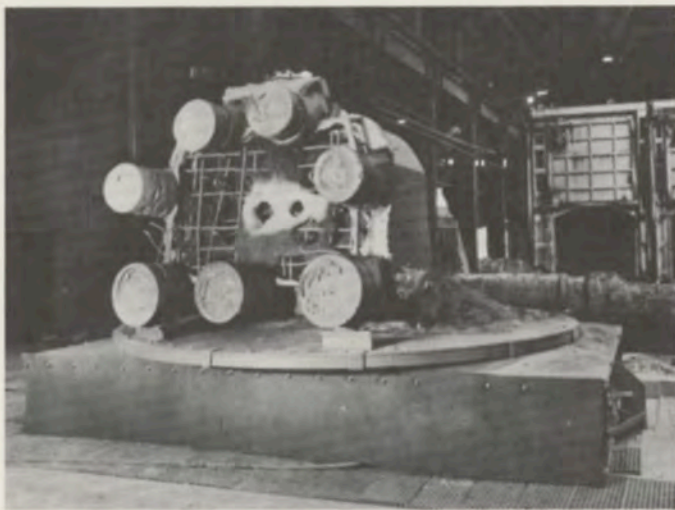

Fig. 9

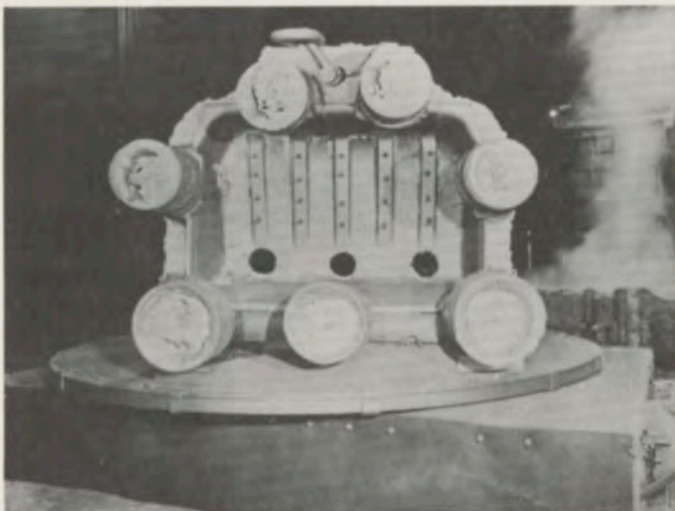

Fig. 10

Another new development is blast cleaning of extremely hot castings. At several foundries, cast steel railroad car wheels are cleaned soon after pouring. The wheels are 1400 degrees when they go through the blast cleaning machine. It takes about 30 seconds to clean each wheel. 230 to 250 wheels a day are cleaned in each special blast cleaning machine (Fig. 11). After the initial cleaning, the wheels go to a soaking pit, are heat treated, cooled and recleaned in another blast cleaning machine.

Removal and recovery of tons of sand used in the stack moulding of non-ferrous plumbing fixtures is another job being done by blast cleaning equipment. As castings come from the pouring station they are transferred, still hot, to a specially designed, slat conveyor type of blast cleaning machine (Fig. 12). Sand is removed from the abrasive in a separator and then discharged to a sand mixing unit for re-use. More than 7000 molds are cleaned daily in a two shift operation. After sorting and grinding, the individual castings are given a final cleaning in two 7 cubic foot. batch type blast cleaning machines.

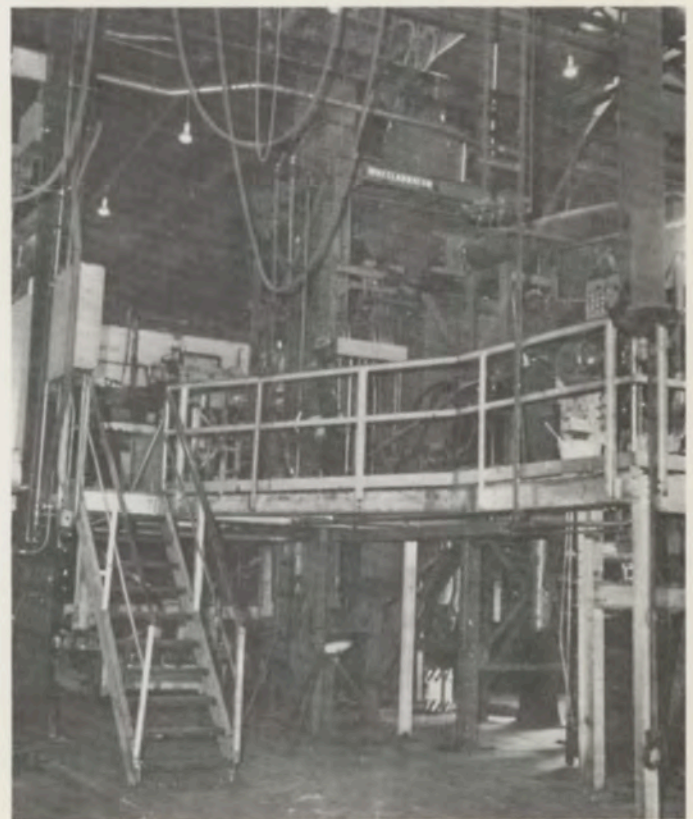

Fig. 11



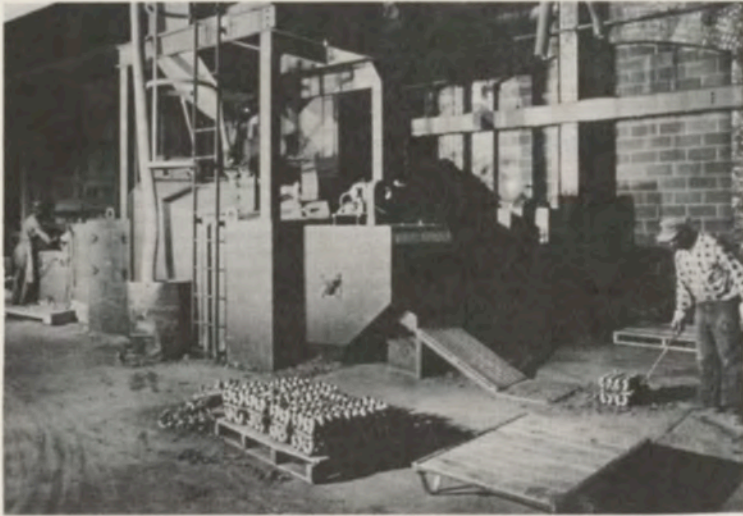

Fig. 12

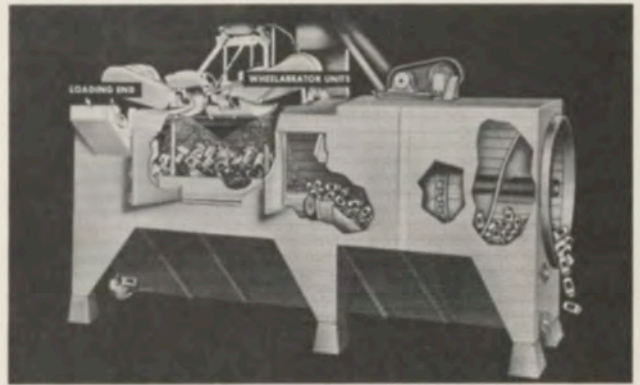

Fig. 13

The ultimate in automated cleaning of castings, which can be tumbled, is obtained with Continuous Tumblast type of cleaning machine (Fig. 13). Cleaning is completely automatic and continuous with no labor required. Important man hours can be saved in handling, sorting, and operating of equipment. Loading operations can be conveyORIZED and production speeds can be geared to any needs. Work passes through the rotating mill in a continuous flow, passing beneath the abrasive blast of two overhead wheel units.

Continuous, high production blast cleaning of castings that cannot be tumbled is accomplished in monorail type blast cleaning machines (Fig. 14). Depending on the nature of the castings, and production requirements, monorail machines can be equipped with any number of abrasive throwing units and conveyor arrangements through the machine. Castings may pass through the machine at a constant speed or may be stopped and spun in front of each blast wheel. As an example of the monorail machines high production capacity, one foundry hangs seven 60 pound crankshafts on each monorail hanger every 55 seconds resulting in production of over 420 crankshafts hourly.

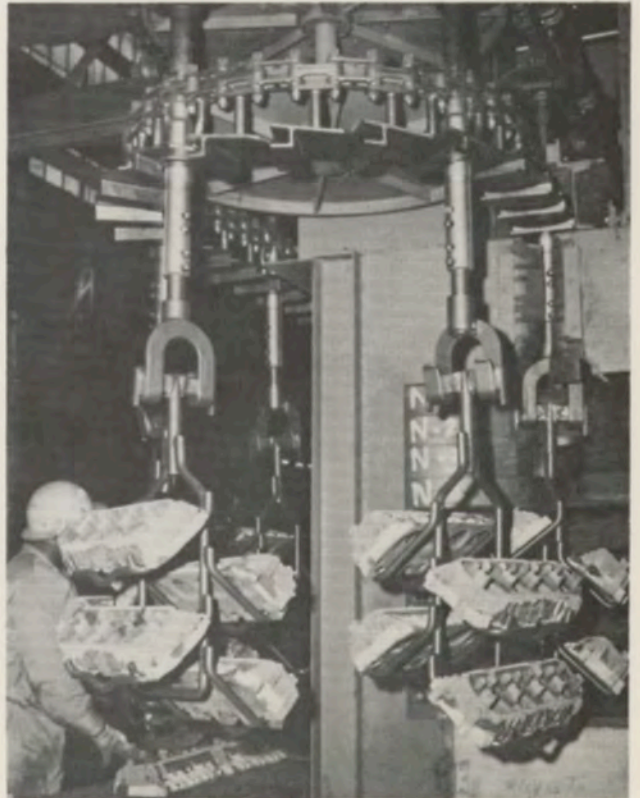

Fig. 14



Where production requirements are such that a high production monorail machine cannot be justified, the advantages of this blast cleaning method are available in a relatively new blast cleaning machine development, the spinner hanger machine (Fig. 15). At one foundry, relatively brittle high tensile gray iron castings, which, due to breakage, were unsuitable for cleaning in batch type machines, are cleaned in the spinner hanger machine. Up to 34 pieces are loaded on a hanger fixture at the front

of the machine. The casting laden hanger then moves into the blast chamber and rotates in front of two abrasive throwing wheels. After cleaning, the hanger moves to the front of the machine for unloading. Cleaning times are 2 to 4 minutes for hanger loads weighing up to 400 pounds.

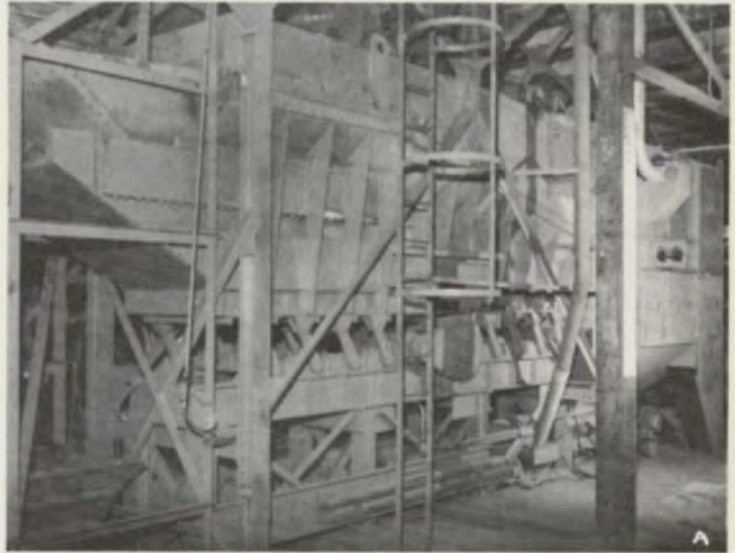

Fig. 16



Fig. 15

Because malleable castings prior to annealing fracture easily, breakage rates in conventional batch type or continuous blast machines has made cleaning of hard iron a problem. An adaption of the Continuous Tumbast type of machine is being currently used to clean prior to annealing (Fig. 16). This unusual machine has a step-down shaker conveyor in place of the endless mill. The gentle action of the three level shaker conveys the castings through a blast zone without the usual breakage. From the blast cleaning machine, the castings discharge to a belt conveyor leading past a series of sorting stations, for inspection and segregation by type. One of the foundries, where this kind of hard iron cleaning machine has been operating, claims savings of well over \$200,000 in the first two years of operation. The savings come from an actual reduction of scrap and elimination of further processing of defective castings. Hard iron cleaning also facilitates cleaning of the castings after annealing.



Automotive cylinder heads, manifolds and transmission housings are difficult castings to clean. Cylinder heads, for example, have cavities, ports and corners that depend, to a great degree, on rebounding abrasive for acceptable cleaning. Each casting must be subjected to intense direct abrasive blast for the full length and complete periphery of the casting. Although monorail blast cleaning machines were being used, production rates were not high enough and better cleaning quality was desired. To meet specific requirements of high production foundries making only a few kinds of castings, the Ram-Roll machine was developed (Fig. 17).

The completely automatic operation begins when "cage" carriers are brought to the machine and positioned at the loading station. Castings are conveyed to the loading station and fixtured in the carriers. The carrier and casting are ramped onto a pair of parallel rotating rolls extending through the machine. An air cylinder operated ram then pushes the carrier into the blast chamber where the casting is rotated under the blast of multiple abrasive throwing wheels. After cleaning, the casting is automatically removed from the carrier and both casting and carrier are ejected from the machine. The carrier returns to the loading station and the operation repeats itself. One Ram-Roll machine is currently cleaning 750 cylinder heads an hour. Manifolds are cleaned at the rate of 600 an hour and 450 transmission housings an hour are deburred at other installations of this radically new type of blast cleaning machine. Another version of the Ram-Roll machine utilizes a single carrier, permanently positioned in the machine, in place of the multiple carrier system. The type of carrier system used is governed by several factors including the configuration of the casting.

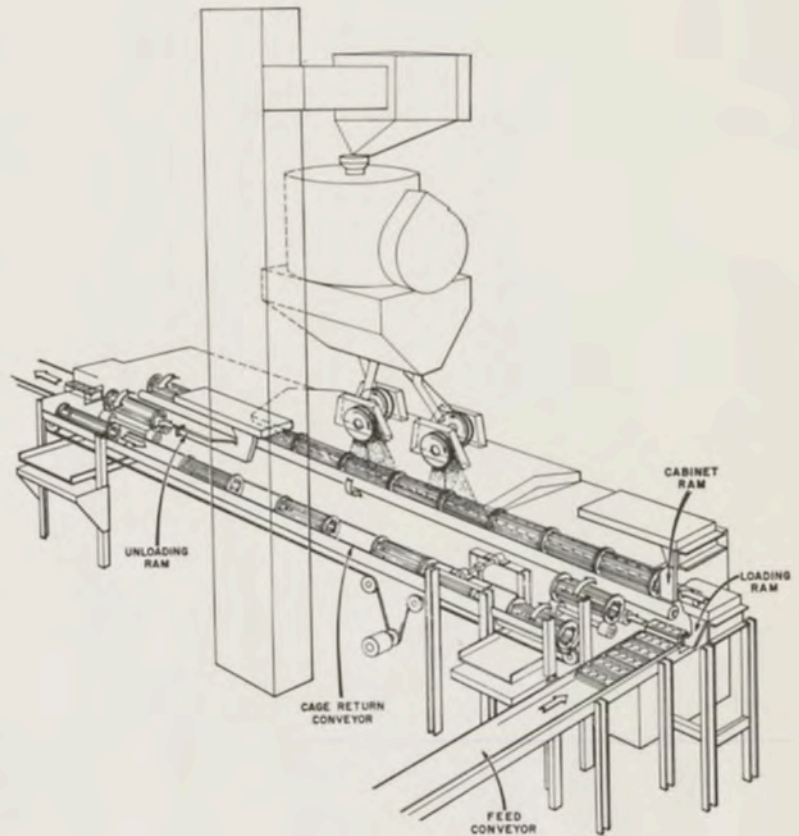

Fig. 17

These few illustrations of modern blast cleaning operations typify how many foundries are reducing costs and increasing cleaning room production through the use of new blast cleaning equipment. If your blast cleaning equipment is more than 10 years old, an improved model of the same kind of machine, or an entirely new blast cleaning method, has probably been developed.